

1969 Moto Guzzi U750 European

27 October 2005

Carl Allison

Drawing is sized to print as  
letter size at 100%

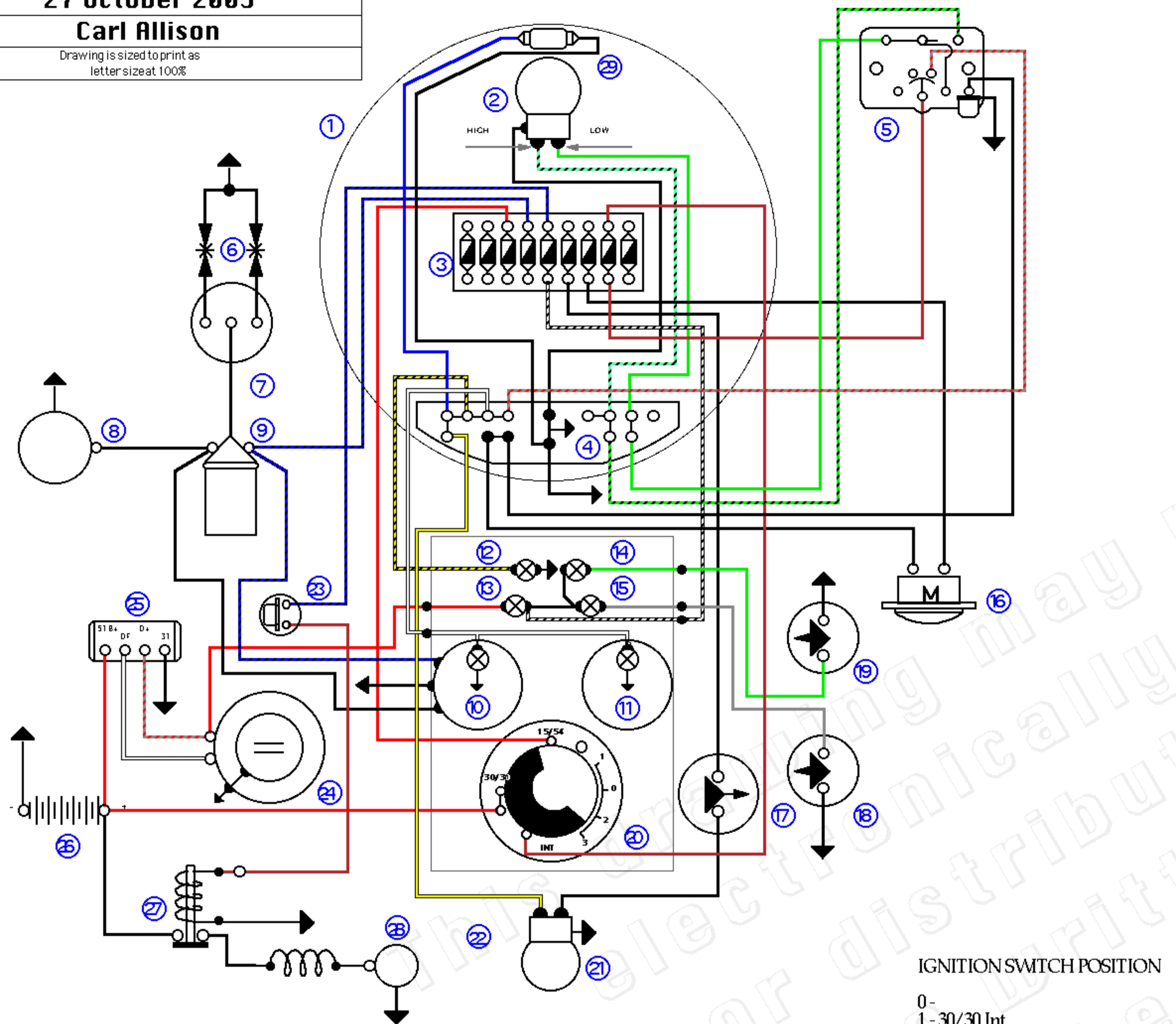

IGNITION SWITCH POSITION

- 0-
- 1- 30/30 Int.
- 2- 30/20 Int. 15/54
- 3- 30/30 Int. 15/54 50

LEGEND

- 1. Headlight
- 2. Main light bulb
- 3. Terminal block with fuses
- 4. Distributing block
- 5. Light switch and horn button
- 6. Spark plug
- 7. Distributor
- 8. Contact breaker
- 9. Ignition coil
- 10. Tachometer
- 11. Speedometer
- 12. High beam indicator
- 13. Generator warning light
- 14. Neutral indicator
- 15. Oil pressure warning indicator
- 16. Horn
- 17. Stop light switch
- 18. Neutral indicator switch
- 19. Oil pressure switch
- 20. Ignition switch
- 21. Number plate and tail light
- 22. Plate illumination and stop light
- 23. Starter motor switch
- 24. Generator
- 25. Regulator
- 26. Battery
- 27. Starter motor relay
- 28. Starter motor
- 29. Parking light

1969 Moto Guzzi U750 USA

27 October 2005

Carl Allison

Drawing is sized to print as  
letter size at 100%

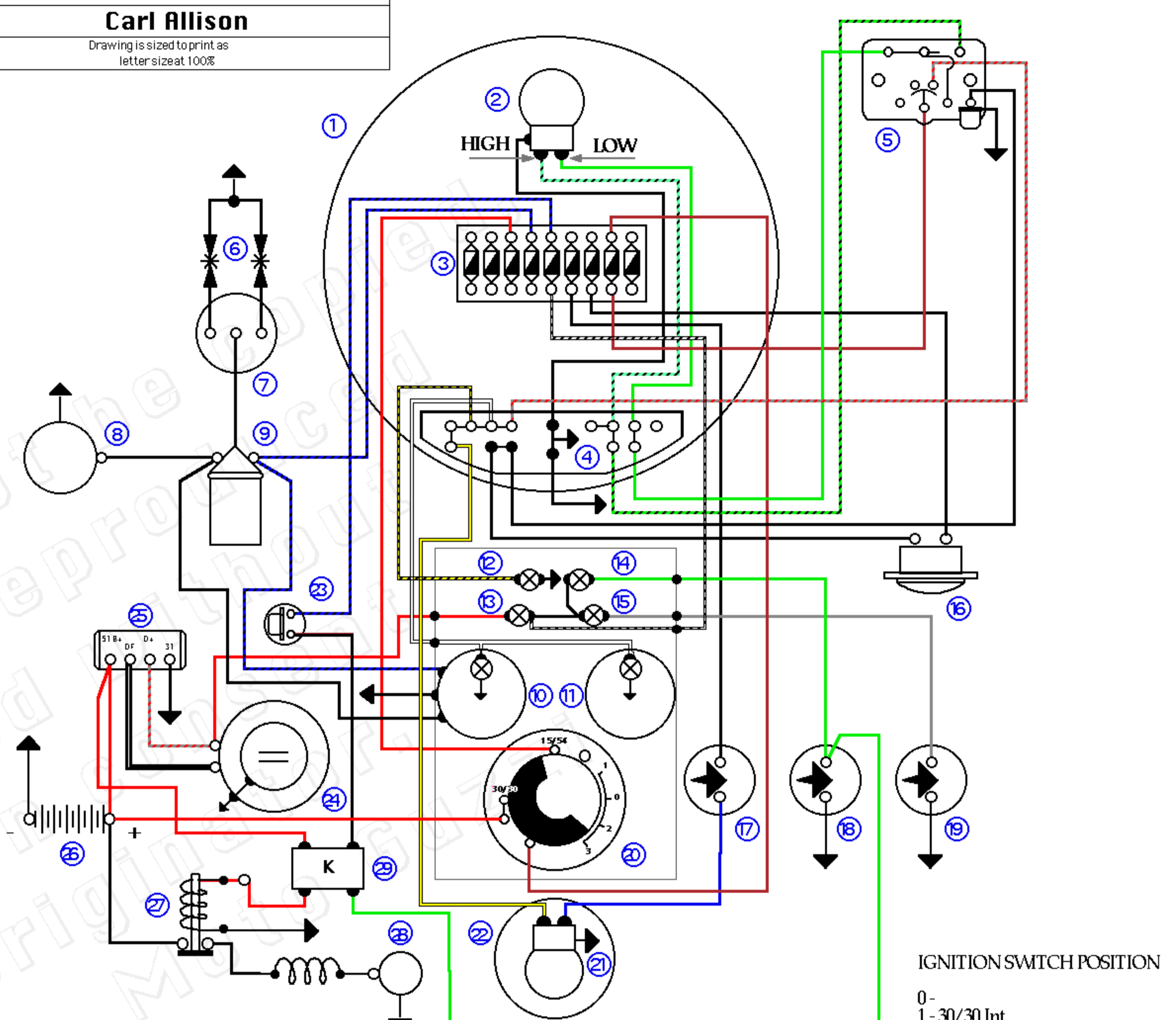

IGNITION SWITCH POSITION

- 0-
- 1- 30/30 Int.
- 2- 30/20 Int. 15/54
- 3- 30/30 Int. 15/54 50

LEGEND

- 1. Headlight
- 2. Main light bulb
- 3. Terminal block with fuses
- 4. Distributing block
- 5. Light switch and horn button
- 6. Spark plug
- 7. Distributor
- 8. Contact breaker
- 9. Ignition coil
- 10. Tachometer
- 11. Speedometer
- 12. High beam indicator
- 13. Generator warning light
- 14. Neutral indicator
- 15. Oil pressure warning indicator
- 16. Horn
- 17. Stop light switch
- 18. Neutral indicator switch
- 19. Oil pressure switch
- 20. Ignition switch
- 21. Number plate and tail light
- 22. Plate illumination and stop light
- 23. Starter motor switch
- 24. Generator
- 25. Regulator
- 26. Battery
- 27. Starter motor relay
- 28. Starter motor
- 29. Neutral switch relay